

CAPACITALK

MYRON ZUCKER ^{INC}

36825 Metro Court • Sterling Heights, MI 48312-1013

Phone: (586) 979-9955 • Fax: (586) 979-9484 • Website: www.myronzucker.com

No. 100

Wiring of Power Factor Capacitors — What Could Be Simpler?

Today, with so many different types of motors and circuits in the plant, it becomes very difficult to determine where to wire power factor capacitors.

In the “old days,” with just across-the-line starters, the capacitor was wired between the contact and the overload of the starter, and it was done. But today, with high-efficiency motors, non-linear loads, drives and such, wiring of the capacitor becomes a very different story.

Consideration must be given to the application of the capacitor and its wiring in the system.

Future issues of *Capacitalk* will cover various applications and will serve as a guide to the wiring of power-factor capacitors. This *Capacitalk* issue begins with across-the-line, full-voltage starters. Other issues will focus on reversing, two-speed, soft-start starters and many more.

Across-the-Line, Full-Voltage Starters

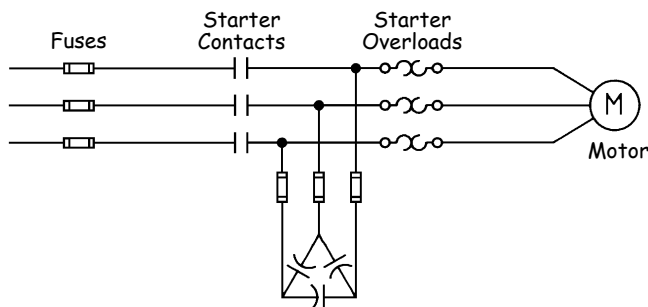

Figure 1

Connect the capacitor leads in parallel with the motor circuit between the overloads and the starter contacts. This is the simplest connection for the capacitor.

When the motor is energized, the capacitor is energized. When the motor is de-energized, the capacitor is de-energized.

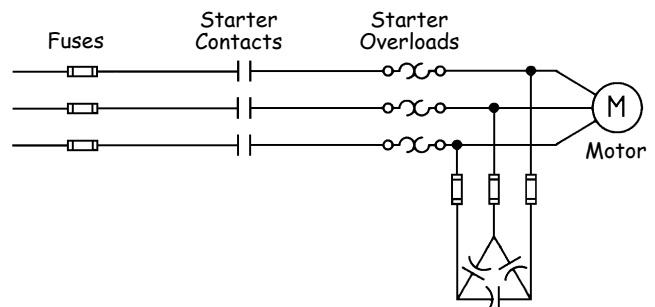

Figure 2

When it is not possible to connect between the contacts and the overloads, then the capacitor may have to be connected between the overload and the motor. But remember to reduce the overload current setting. With the capacitor connected here, the overload will see less current. Care must also be given to sizing the capacitor

(continued on back)



Across-the-Line, Full-Voltage Starters

(continued from front)

accurately. The motor may be damaged if the capacitor is too large. In some motors with rotor/impellers, when the motor is de-energized, the capacitor is still connected to the motor. The rotor/impeller assembly, with its substantial inertia, continues rotating even though the motor is no longer energized. The motor then becomes a generator capable of delivering a sizable amount of rotative power. The capacitor is, therefore, continuously being recharged by the motor-generated voltage. The voltage at the capacitor can reach excessive levels. At this point, there can be insulation failure at the weakest point in the system—the motor, capacitor, starter or the interconnecting wiring.

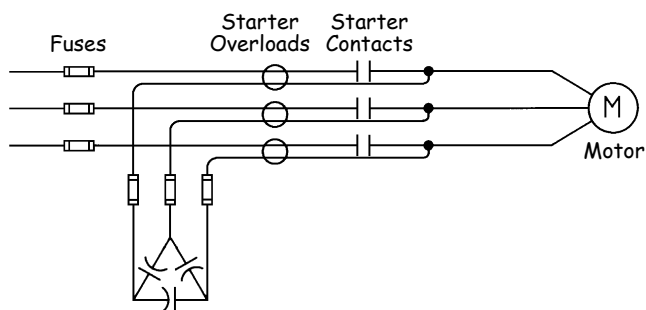

Figure 4

If the overload device is upstream of the capacitor connection, the leads of the capacitor should be routed through the overload. The overload device then recognizes the motor current and the capacitor current, so no reduction of the overload is required.

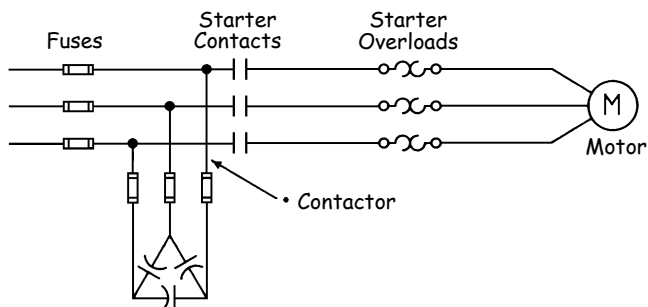
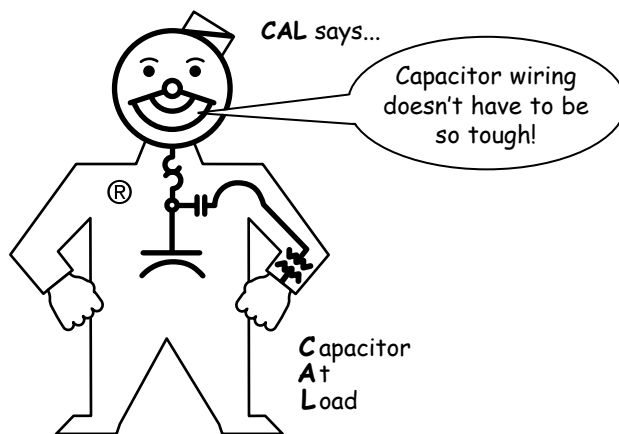

Figure 3

Sometimes it may not be possible to connect the capacitor between the starter contacts and the overload. The capacitor may have to be connected between the fuse and the starter contacts. This type of connection is called “floating” the capacitor (capacitor is energized all the time). Depending on the application, a contactor may be added to energize the capacitor after the motor has been energized. One benefit of floating the capacitor is gained with high-efficiency motors where the fuse may be a little undersized for a heavy-loaded start. With the capacitor already energized, the capacitor sees the motor as a short and releases its energy into the motor to help it start. This makes the motor fuse experience less inrush current and helps avoid nuisance fuse tripping on startup.

These four (4) connections offer the best of both worlds. Not only is the power factor of the motor improved, but improvements are also achieved in total plant power factor. Remember that power factor capacitors work from point of attachment in the system back upstream to the main transformer feeding the system. So, with the capacitors attached at the motors, full benefits are gained from unloading the entire system and from reduced I²R losses.



MYRON ZUCKER ^{INC}

36825 Metro Court • Sterling Heights, MI 48312-1013
 Phone: (586) 979-9955 • Fax: (586) 979-9484 • Website: www.myronzucker.com

